

## MERKMALE UND VORTEILE

### CONSTRUCTION

Unit is made of 18 gauge Type 304 stainless steel with a satin finish that resists stains and corrosion, and has soft, rounded corners. Unit features stainless steel satin finish back panel, vandal-resistant bottom plate, and 1-1/4" integral trap.

### FREEZE-RESISTANT VALVE

Fully engineered system with the pneumatic-operated, freeze-resistant valve mounted in a cabinet that is installed on the inside wall where room temperature does not drop below 50° F (10° C). When valve goes to off position, water left in supply line between valve and bubbler drains back into waste inside cabinet, protecting the unit from freezing, and allowing fountain to function year-round.

### BUBBLER HEAD

Polished chrome-plated brass bubbler head with integral basin shank for added strength. Shielded, angled stream opening provides a steady, sanitary source of drinking water at .45 gpm.

## OPTIONEN

- Freeze-Resistant Bottle Filler: Model 1920FR, freeze-resistant bottle filler can be a stand-alone wall mounted station, or mounted over the 1109FR & 1119FR series fountains.
- Support Frame: Model 6800 universal in-wall mounting support for use with most fountains.
- Mounting Plate: Model 6700 universal mounting plate for most wall mounted fountains. Priced Separately.
- Back Panel: Model BP3, satin finish stainless steel back panel.

Weitere Informationen erhalten Sie unter [www.haws.ch](http://www.haws.ch) oder telefonisch unter + 41 (0) 34 420 60 00.



## SPEZIFIKATIONEN

Model 1109FR wall mounted barrier-free drinking fountain shall include an 18 gauge Type 304 Stainless Steel satin finish basin, polished chrome-plated brass vandal-resistant bubbler head, polished chrome-plated brass push-button which a pneumatic valve installed on the inside wall where room temperatures do not drop below 50° F (10° C), self-draining water lines which protect the unit from freezing, polished chrome-plated brass vandal resistant waste strainer, vandal-resistant stainless bottom plate, and 1-1/4" O.D. (3.2 cm) waste pipe.

REQUIRES MODEL 6521FR PRICED SEPARATELY.

## ANWENDUNG

Perfect for either public or private outdoor settings, Model 1109FR is a great fit in areas where aesthetics are important to the overall appeal of the architecture. Beautiful satin finish helps to maintain the fountains overall appeal. Specifically, this type of wall mounted drinking fountain may be placed in settings such as: parks, schools, and other facilities where the temperature may drop into freezing conditions.

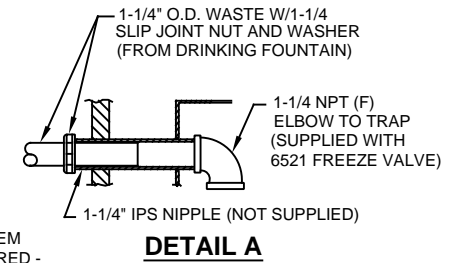
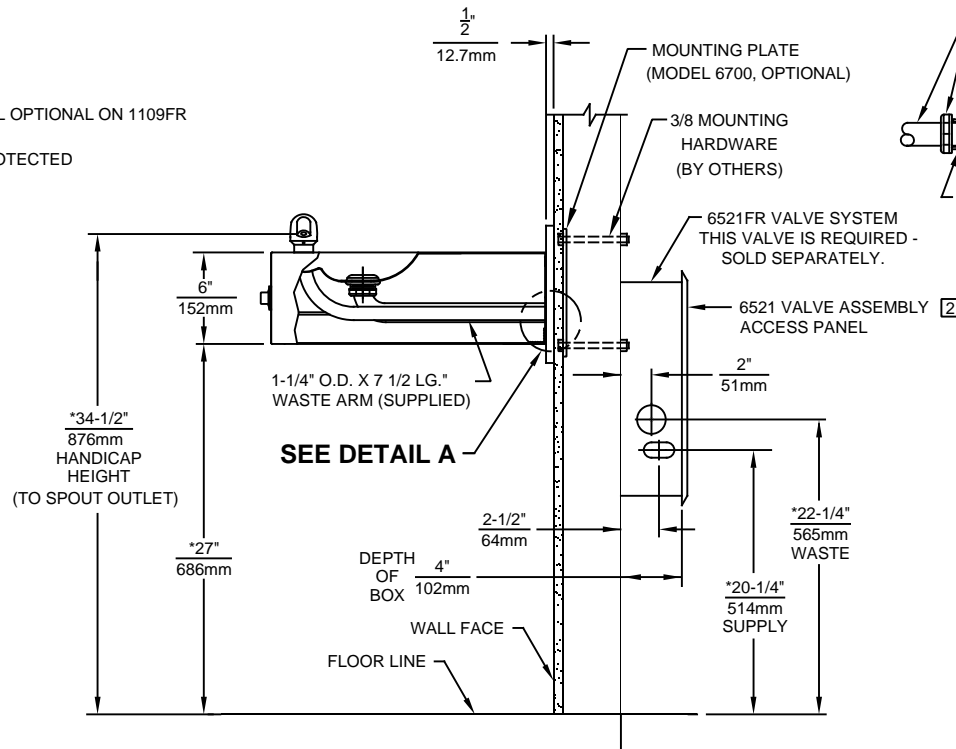
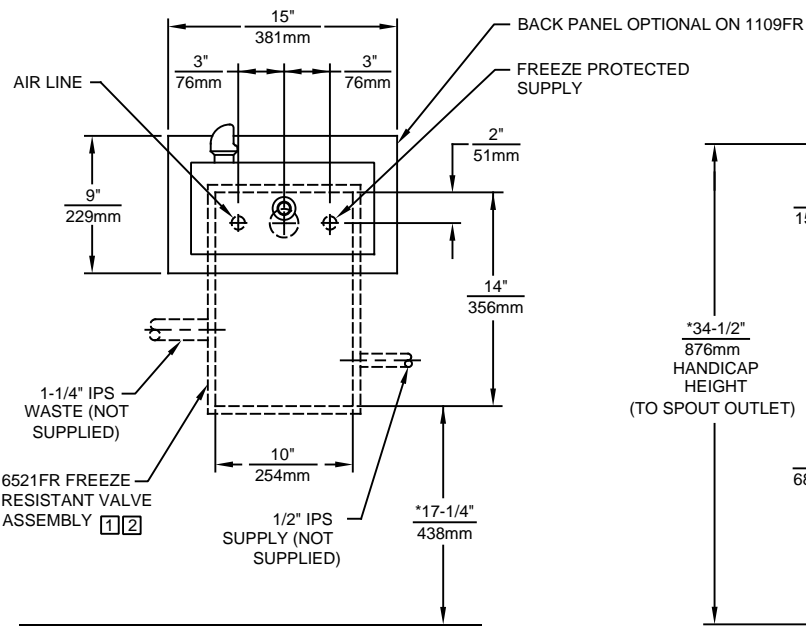
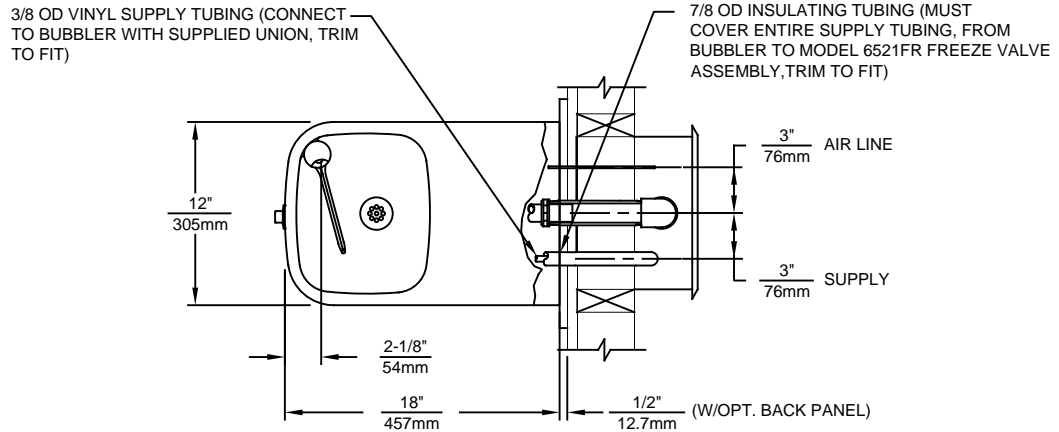
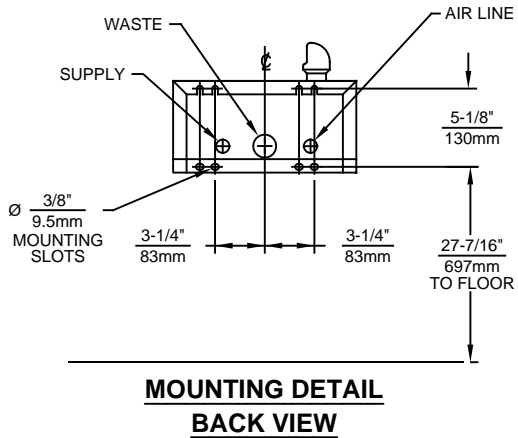

NOTES:

- 1 THIS FOUNTAIN REQUIRES THE USE OF MODEL 6521FR FREEZE RESISTANT VALVE ASSEMBLY (SOLD SEPARATELY)
- 2 VALVE ASSEMBLY MUST BE INSTALLED IN A WARM AREA. PROVISIONS SHOULD BE MADE TO ALLOW ACCESS TO ACCESS PANEL
3. HOLD ROUGH-IN DIMENSIONS  $\pm 1/4"$  (6.4mm).
4. \* WHEN INSTALLING THIS UNIT LOCAL, STATE OR FEDERAL CODES SHOULD BE ADHERED TO. FOR INSTALLATION HEIGHTS OTHER THAN SHOWN, DIMENSIONS MARKED (\*) MUST BE ADJUSTED ACCORDINGLY.

1455 KLEPPE LANE  
SPARKS, NEVADA 89431  
(775) 359-4712 FAX (775) 359-7424  
E-MAIL: HAWS@HAWSCO.COM  
WEBSITE: WWW.HAWSCO.COM

ECN NO.	REVISED PER	BY:	MODEL(S)	PART NUMBER
	ECN: 5527	FV	1109FR	0002076626.D
DRAWN:	DATE:	CHKD.:		REVISION
F.V.	06-01-98	DP		15
APPROVED:	DATE:	SCALE:	DRAWING TYPE:	SHEET 1 OF 1
FV	04/02/20	1:16	INSTALLATION	