

REVISIONS				
REV	DESCRIPTION	ECN	DATE	BY
1	INITIAL RELEASE	5456	10/17/2019	JJ

- NOTES:
1. DIMENSIONS IN INCHES.
 2. ALL TOLERANCES: $\pm 1"$
 3. MATERIAL:
 PIPE: 304 SST
 FITTINGS: 304 SST
 BALL VALVE: 316 SST
 PRESSURE REGULATING VALVE: LEAD FREE BRONZE
 LEAD FREE BRASS WATER HAMMER ARRESTOR
 Y-STRAINER: 316 SST
 5. ESTIMATED WEIGHT:
 WET: 30 LBS

PIPING KIT CONFIGURATOR		
MODELS	WATER HAMMER ARRESTOR SIZE	LEGS
932X-11	B (15' pipe length from header to shower)	No
932X-21	C (15'-30' pipe length from header to shower)	No
932X-31	D (30'-50' pipe length from header to shower)	No
932X-41	E (50'-75' pipe length from header to shower)	No
932X-51	F (75'-90' pipe length from header to shower)	No

(HEATER SHOWN FOR REFERENCE)

WATER HAMMER ARRESTOR
(SEE TABLE FOR SIZE)

CUSTOMER CONNECTION
TEMPERED WATER OUTLET
1-1/4" NPT UNION
SHOWER TO BE NO FARTHER
THAN 10FT AWAY FROM
WATER HAMMER ARRESTOR

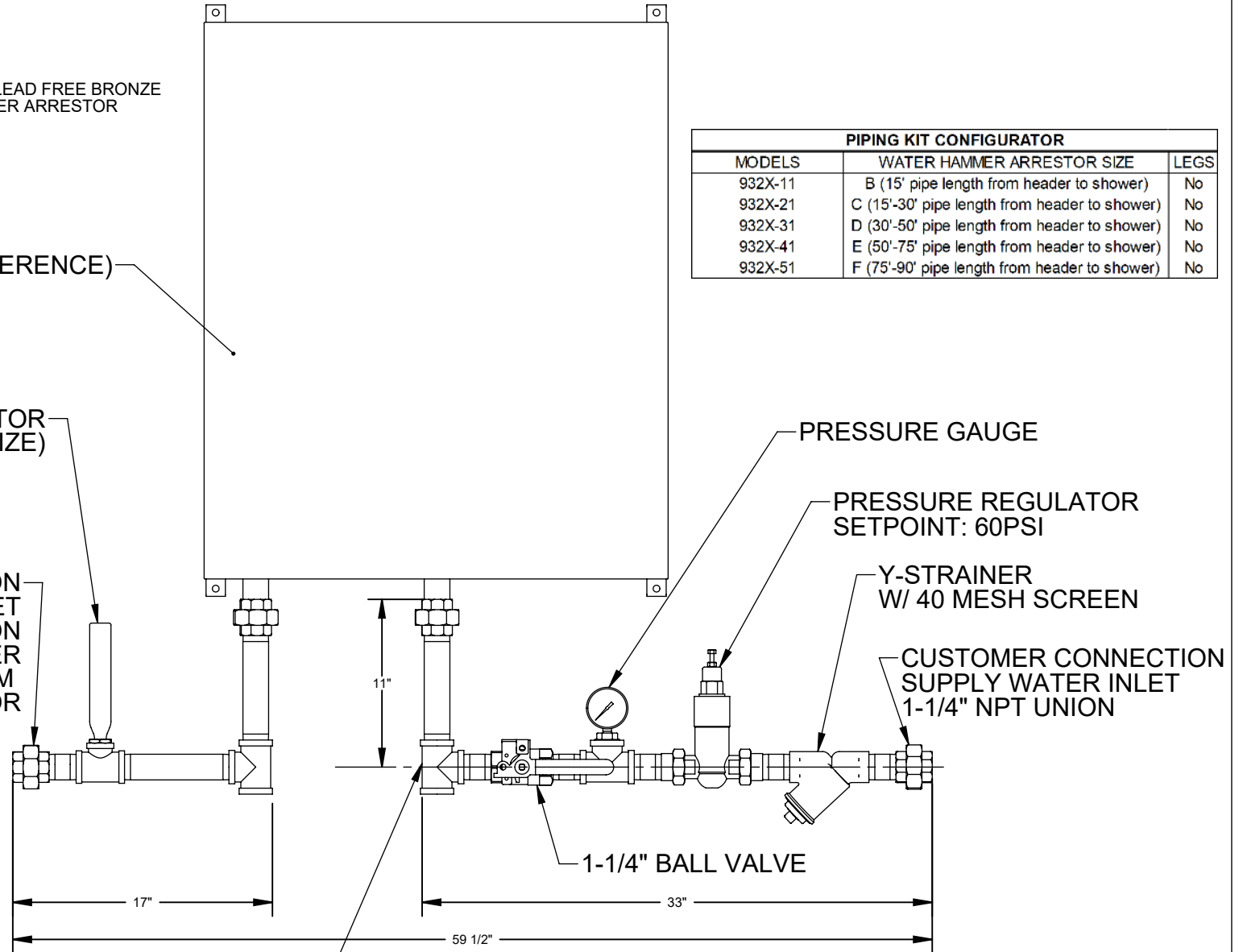

PRESSURE GAUGE

PRESSURE REGULATOR
SETPOINT: 60PSI

Y-STRAINER
W/ 40 MESH SCREEN

CUSTOMER CONNECTION
SUPPLY WATER INLET
1-1/4" NPT UNION

1-1/4" BALL VALVE

TEE WITH DRAIN
(BOTH LINES)

1455 KLEPPE LANE
SPARKS, NEVADA 89431
(775) 359-4712 FAX (775) 359-7424
E-MAIL: HAWS@HAWSCO.COM
WEBSITE: WWW.HAWSCO.COM

ECN: 5456	REV. ECN: 5456	BY: JL	MODEL(S) 932X - HEATER PIPING KIT	PART NUMBER 051000981.D
DRAWN: JL	DATE: 10/08/19	CHKD: DW		REVISION 1
APPROVED: NE	DATE: 11/07/19	SCALE: 1:10	DRAWING TYPE: INSTALLATION	SHEET 1 OF 2

NOTES:

1. DIMENSIONS IN INCHES.
2. ALL TOLERANCES: ±1"
3. MATERIAL:
 - PIPE: 304 SST
 - FITTINGS: 304 SST
 - BALL VALVE: 316 SST
 - PRESSURE REGULATING VALVE: LEAD FREE BRONZE
 - LEAD FREE BRASS WATER HAMMER ARRESTOR
 - Y-STRAINER: 316 SST
5. ESTIMATED WEIGHT:
 - WET: 40 LBS

PIPING KIT CONFIGURATOR		
MODELS	WATER HAMMER ARRESTOR SIZE	LEGS
932X-12	B (15' pipe length from header to shower)	Yes
932X-22	C (15'-30' pipe length from header to shower)	Yes
932X-32	D (30'-50' pipe length from header to shower)	Yes
932X-42	E (50'-75' pipe length from header to shower)	Yes
932X-52	F (75'-90' pipe length from header to shower)	Yes

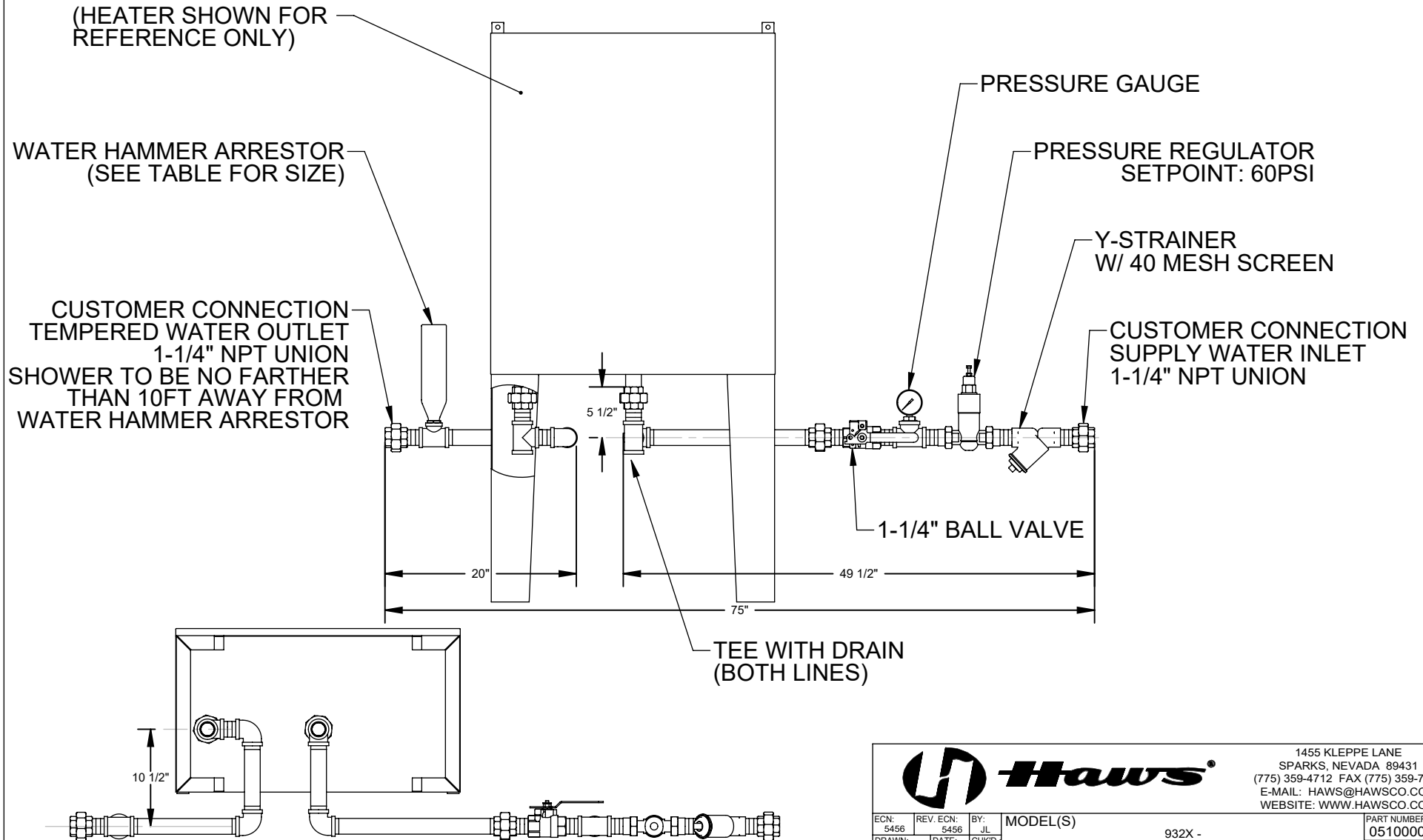

1455 KLEPPE LANE
SPARKS, NEVADA 89431
(775) 359-4712 FAX (775) 359-7424
E-MAIL: HAWS@HAWSO.COM
WEBSITE: WWW.HAWSO.COM

ECN: 5456	REV. ECN: 5456	BY: JL	MODEL(S) 932X - HEATER PIPING KIT	PART NUMBER 051000981.D
DRAWN: JL	DATE: 10/08/19	CHKD: DW		REVISION 1
APPROVED: NE	DATE: 11/07/19	SCALE: 1:15	DRAWING TYPE: INSTALLATION	SIZE: A SHEET 2 OF 2